

Interoperable Communications, Alerting and Notification Systems in Healthcare

Federal Signal Corporation

Published: August 2008

Abstract

Interoperable communications, alerting and notification systems enable the convergence and integration of previously separate communication channels that include, fixed and mobile networks and devices, paging and sensing devices and systems, along with the management controls and reporting capabilities that surround them. Increasingly, hospital and medical facilities realize that separate communications applications can be combined with one another and with patient applications to make their communications faster and more effective, offering them fail-safe communications in their respective departments.

Federal Signal - Codespear understand that people, not processes, are the key to success, whether success is measured by healthy patients, improved healthcare delivery, improved responsiveness or a healthy bottom line. It is crucial that healthcare and safety workers have access to the information and communications they need to guide their actions that these solutions are available when those workers need it, from wherever they happen to be, and that collaboration for decision making is seamless and intuitive.

This Interoperable Communications in Healthcare White Paper is for informational purposes only. Federal Signal Codespear makes no warranties express, implied or statutory, as to the information presented in this white paper document.

Federal Signal may have patents, patent applications, trademarks, copyrights, or other intellectual property rights covering subject matter in this document. Except as expressly provided in any written license agreement from Federal Signal, the furnishing of this document does not give you any license to these patents, trademarks, copyrights, or other intellectual property.

If you have comments on this publication or would like additional information from Federal Signal please contact us at publicsafety@federalsignal.com

© 2008 Federal Signal Corporation. All rights reserved.

The names of actual companies and products mentioned herein may be the trademarks of their respective owners.

Contents

Introduction..... 1

Codespear Solution..... 2

Where can Codespear Help in Healthcare? 5

How are customers using Codespear in Healthcare? 6

Purchasing Considerations 9

Summary and Next Steps 11

Introduction

The purpose of this white paper is to provide an overview of the collective Federal Signal Codespear efforts to provide alerting and notification enabling solutions to improve the hospital and medical facility safety, security, and overall communications for those working in and around the facility.

Interoperable communications, alerting and notification systems enable the convergence and integration of previously separate communication channels, fixed and mobile networks and devices, and paging and sensing devices and systems, along with the management controls and reporting capabilities that surround them. Increasingly, hospital and medical facilities realize that separate communications applications can be combined with one another and with patient applications to make their communications faster and more effective, offering fully integrated fail-safe communications in their respective departments.

Interoperable communications, alerting, and notification systems are often categorized into the unified communications space which is evolving communications technology architecture. Its purpose is to optimize processes and enhance human communications by reducing latency, managing work flows, and eliminating device and media dependencies.

Unified communications can include a variety of elements, such as radio communication, instant messaging, telephony, video, email, voicemail, and short message services, whiteboarding all of which could be brought into real time and coordinated. The concept of presence is also a factor – knowing where one’s intended recipients are and if they are available, in real time – and is itself a key component of unified communications. The goal is for unified communications to integrate all the systems that a user might already be using and helps those systems work together in real time.



Unified communications is sometimes confused with unified messaging, but it is distinct. Unified communications refers to a real-time delivery of communications based on the preferred method and location of the recipient; unified messaging systems culls messages from several sources (such as email, voice mail and faxes), but holds those messages for retrieval at a later time.

To this end, Federal Signal - Codespear have developed the Healthcare interoperable communications, alerting, and notification vision which encompasses the needs of healthcare providers, healthcare facilities, and the life sciences community, the major verticals of the healthcare and life sciences ecosystem along with the safety, security, and facilities management. Fulfilling the vision relies on innovative technology—including both out-of-box Codespear products and custom solutions developed with our partners—that enable workers to connect with the information they need; use that data to collaborate with other people, departments, and enterprises; and then develop business intelligence based on situational awareness that helps improve communications and decision making.

Codespear Solution

Codespear provides a mission-critical communications and nerve center platform, supporting secure communications interoperability, urgent alert notification, incident scenario management and execution, event monitoring, cross-agency data sharing and collaboration. The solution is a redundant system that can be rapidly deployed in stationary and mobile configurations, occupies a small and agile footprint, and requires only DC battery power to operate.



Codespear includes several easy to use modules that you may choose to deploy together or as individual components of the overall solution. This includes:

SmartMsg — Industry leading software-centric solution that provides comprehensive communications interoperability among multiple agencies and communication devices. Disparate, non-interoperable communication hardware has caused doctors, nurses, hospital administrator, safety and security personnel significant difficulty in communicating with each other, and there is still no real solution in place. In addition to the need for interoperable, live communications, public safety institutions must have the ability to broadcast time-sensitive alerts to both target groups and mass citizenry. SmartMsg includes several key features to enable everyday use of your communications systems.

Scenario Manager — The Scenario Manager is an add-on module to the SmartMsg solution. Scenario Manager provides for automating emergency and incident procedures. An agency is able to pre-define automatic procedures (scenarios) for various events based on its own particular needs. Scenarios may include any series of actions including broadcasting alerts, evaluating alert responses, pulling in data from external systems, creating talk groups, activating standby channels and more.

SmartMsg remote interoperability unit (RIU) — The RIU is an add-on module to SmartMsg that provides an embedded voice-over-IP (VoIP) architecture and enables the simultaneous text and voice broadcast of alert notifications to two-way radios, push-to-talk (“PTT”) enabled devices, PCs, phones, pagers, overhead paging systems and wireless PDAs. The radio

“The Codespear system has brought about REAL benefits to the District in terms of improved response times, improved patient care, compliance, as well as significant time savings for basic administrative communications,” says John Waters of Ingham Regional, “It has been a sound investment; the Codespear solution is built on a platform that can grow and change with our needs, and the fact that Federal Signal has put its name on the product lets us know that we can rely on this product for a long time to come.”

interoperable device also enables integrated real-time communication between two-way radio talk groups, PTT groups, phone devices and PCs. This solution supports radios from different manufacturers, across multiple bands and frequencies (including HAM), and pre-defined talk groups. The RIU consists of a compact hardware appliance and a standard PC configuration, which also can operate as a standard server. Once a radio is docked into the RIU appliance, the VoIP architecture effectively enables that radio as a secure virtual repeater. The RIU device also has the ability to function as a sensor unit for remote

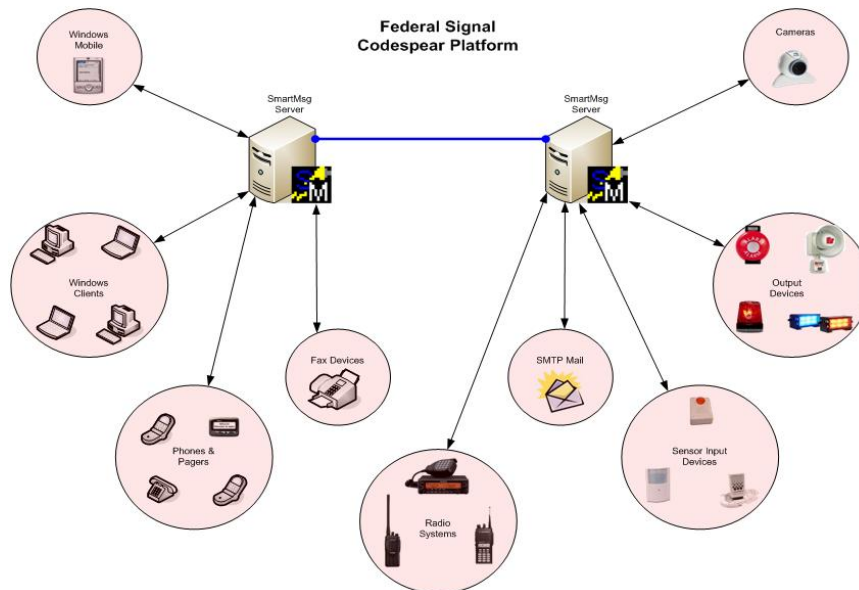

monitoring of situations integrating trip wires, sensors, and video.

Dispatch Console — The Dispatch Console is an add-on module to the SmartMsg Solution. The Dispatch Console is a client tool used to facilitate and organize

multiple communication groups, with the added ability to set audio options and audio playback. It also supports video communication. It allows the user to set up and communicate with Talk Groups and Standby Channels. The Dispatch Console is useful for communicating with large amounts of users instantly.

GIS Console — The GIS (Geographical Information System) Console is an add-on module to the SmartMsg solution. It is intended for use to send alerts based on geographical areas. The GIS Console allows for SmartMsg alerts to be sent to target areas, with the alert going out to all SmartMsg recipients within the target area coordinates. A user can choose an area on the map to send SmartMsg alerts. To select areas on the map the user can draw circles, rectangles, freeform areas, or select predefined areas of the map like a zip code or county. Specific addresses on the map can also be pinpointed and areas around the point can be selected for sending the alert.



Reaching many different device types with a single message is of major significance for a notification and alerting system. The ability for authorized personnel to send one alert and have it hit everything at once allows for much quicker distribution of messages. A system that provides for broadcasting alerts via various communication mediums is imperative for emergency notifications — if you rely on only one

communication medium and that infrastructure is unavailable during a particular crisis, your system is rendered useless.

Pairing site redundancy with the ability to contact different device types at once provides an elevated level of resilience to a system and a higher probability that communications will get out even during the most disastrous situations when normal communication systems may be crippled.

Codespear Multi-Device Communications Interoperability Deployment

The following diagram depicts an RIU within a distributed and redundant SmartMsg system, allowing communication between the PSTN, PTT capable phone network, computers and disparate radio systems. Codespear's deployment capabilities provide communications interoperability at local and / or geographically dispersed locations and incident sites.

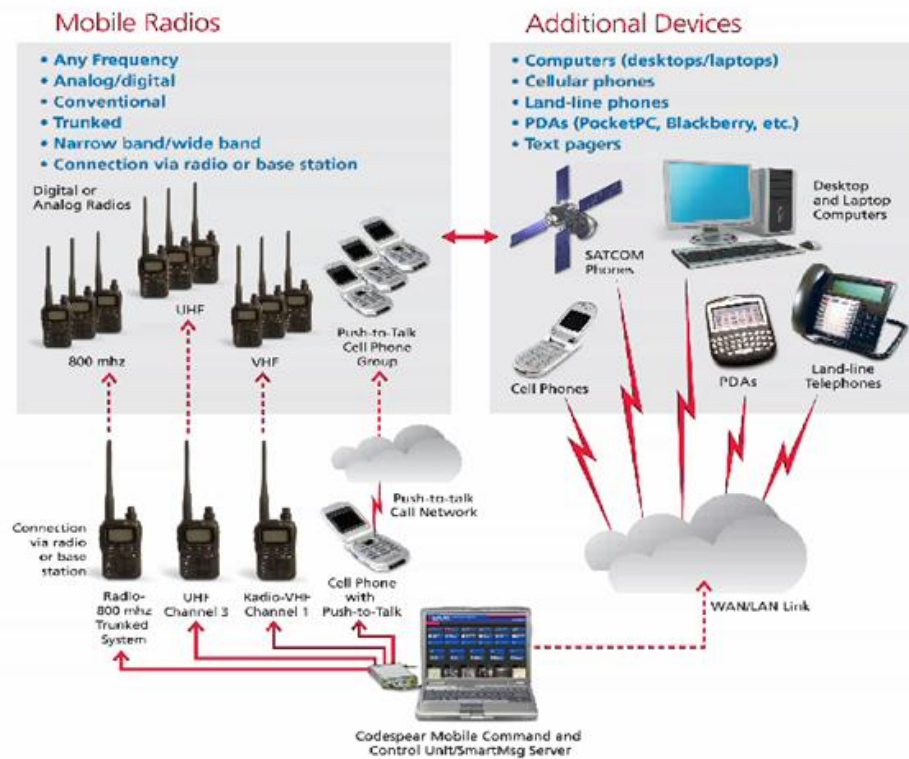

In the next section we will highlight some specific examples of how Codespear can help augment your existing communications systems as well as being used for all of your communications, alerting and notifications needs. This includes a look at day to day uses of Codespear in healthcare as well as a snapshot of how it can be used for emergency situations within your facility.

Where can Codespear Help in Healthcare?

Core to the design of Codespear is the ability to use it for every day communications. This approach insures that in the event of high priority situation that your communications system is so easy to use that you will be able to get your message, alert and notification out to the appropriate people.

Looking at this from a day to day operation perspective our customers have found many uses that help prepare them when the need to respond to an actual emergency situation.

Day to Day Operational	Emergency Situations
Open Shift Notification and Documentation	Safety Alerts (Bomb Threats, Building Evacuation)
IT Alerts	Decontamination Alert and Response
Asset Management (Water, Power, HVAC, High Value Items)	Notification and seamless communications with hospital staff, pre-hospital management, Dispatch Units, Public Health, Fire, Police, EMS, Hazmat
Clinical Alarm Systems	Severe Weather Alerts
High Alert Medications	Crisis / Mass Casualty Alert, Management and Response
Patient Elopement	Fire System Monitoring and Alerting to help comply with Life Safety code compliancy
Asset Management and Security	Emergency Paging/Color-Codes announcements to all required devices including overhead paging
Instant text "chat" communications (B/U to Phone system)	
Video (Motion Detection and Surveillance)	
Joint Commission / Health Department Survey Alert	
"Single Click" Paging Codes (Tied into overhead paging system)	
Monitoring Building Systems (e.g. Water, Power, HVAC)	
Open Shift Notification and Documentation	

One of the core features of Codespear is the open architecture approach that allows Codespear to interoperate with your other existing solutions. This provides an easy way for you to extend the life of your radio systems, cell and handheld devices, as well as other solutions that your employees may use to communicate. Codespear enables an "AND" solution meaning that it is lightweight, flexible, cost effective and easy to get up and running in a very short period of time. In addition it enables your existing communications systems to work together with ease.

How are customers using Codespear in Healthcare?

Ingham Regional Medical Center, McLaren Healthcare

Ingham Regional Medical Center in Lansing, Michigan is one of more than a dozen hospitals, EMS agencies, and other first responder organizations within Michigan's District 1 Regional Medical Response Coalition. In addition to sharing a common goal of providing medical care and first responder services to its citizens, these organizations are also brought together by another common thread – their disparate communication systems were made interoperable by Federal Signal's Codespear Communications Platform.



District 1 had a goal to establish interoperability among its members, and John Waters of Livingston County EMS and chair for the District 1 pre-hospital group, took on the challenge.

“Establishing interoperability among different organizations with different communication infrastructures and devices is typically a very expensive proposition and usually involves a wholesale standardization to a common set of devices that communicate on the

same network frequency,” said John Waters. *“What attracted me to Codespear is that it allowed for me to utilize the existing communication assets of the various organizations, and simply tie them together with Codespear.”*

After evaluating his alternatives, John entered into the first phase of his interoperability deployment by purchasing a Codespear Radio Interoperability Unit (RIU) and 15 licenses of the Codespear SmartMsg Interoperability Software Suite. With this initial deployment, John was able to put to rest the skepticism of many of those around him and successfully interoperated with the 800mhz digital radios with Michigan State Police *“We were instantly able to communicate from any device to any device...cell phones, pagers, UHF radios, VHF radios, land lines, PC's. Voice to text, text to voice, in multiple languages...everyone was amazed.”*

As the proof of the new communication platform was being proven out among the users, the SmartMsg software was also gaining in popularity. Initially used for its chat communication functionality, and for basic alerting and messaging to the 15 users, other uses were quickly found by Byron Callies, Environment of Care Manager for Ingham Regional Medical Center. *“The ease of use and intuitiveness are amazing. Everyone is able to use it, and wants to use it when they understand the capabilities,”* states Byron.

The SmartMsg software is now being used in many areas of the hospital, and finding new uses for it has become a routine part of Byron's role. *“I come across communication problems everyday, and I'm now in the mindset of 'how can Codespear help with this. Much of the time, with Codespear, I'm able to find a solution,”* Byron commented.

Current Applications of Codespear SmartMsg at Ingham Regional Medical Center:

- **Open shift notification** – Managers are able to broadcast open shift notifications to all off duty employees at the click of a button. Depending on the individual employee's notification preferences, that message may go to a home phone, then roll to a cell phone, then perhaps send an email...until it reaches the employee. A benefit to management is that reporting is automatically generated by the system to show how each employee was notified, and on how the employee responded to that notification which can be beneficial in the event that an employee files a grievance that other employees are receiving preferential treatment with regard to open shifts.
- **Emergency paging codes** – Emergency paging notifications can be much more effective. The SmartMsg system can push out a voice message (either computer generated or pre-recorded) to the hospital paging system, while simultaneously sending the notice directly to doctors, nurses, or other individuals involved in the emergency response via cell phone, pager, PDA, email, or any combination. John comments on life before Codespear, "Before we used to just throw out a page and hope it was heard by a few people that would be capable of responding. Today when we send a notification out, we know that it got to the right people and we know how those people are responding. It's a great tool."
- **Panic / Duress Alarms** – Using the Codespear Sensor Board, panic and duress buttons are now interfaced into the Codespear system, enabling real time, reliable notification to security. By using the sensor board as part of the Codespear implementation they were able to streamline communications amongst human resources, dispatch, and campus security. This approach allowed them to eliminate a third party service and save some additional money.
- **Monitoring of Hospital Fire System** – A Codespear sensor board is triggered when the fire system goes down for any reason and an alert is sent out letting everyone know that the system is down. In order to aid in the compliance with NFPA 101 Life Safety Code, a second alert is sent out if the system remains down for 3 hours and 45 minutes...giving management time to respond before falling out of compliance.



The system has grown rapidly due to the satisfaction and success seen by its users. The Region 1 system now has almost 2,500 users on the Federal Signal Codespear Interoperability Platform to broaden the community of first responders and improve communication. In addition to the original users, the system now includes dive teams, civil air patrol, SWAT teams, hostage negotiation teams, canine units, county boards of trustees, and anyone else that may need to be brought into communications during an incident.

Byron comments, *"It is so easy to scale...and it can grow with you, as you have the need and the funding. The fact that it's not tied to devices eliminates any concerns about buying enough radios on the front end...in six months, when you need to add users, you buy the latest and greatest radio, and you know it will work with everything else you have. That makes us feel really good about the Codespear decision, and gives us peace of mind for the future."*

Crittenden Regional Hospital in West Memphis, Arkansas

Crittenden Regional needed advanced interoperability technology to meet the challenges of complex emergencies that cross various organizational boundaries,” said Roy Rogers, manager of information technology at Crittenden Regional. “This Federal Signal critical communications system pairs instant interoperability with urgent notification to bring our first responders together easily and quickly in minutes.”

The Federal Signal SmartMsg system provides first responders with a comprehensive interoperability solution to enable emergency alert notification and live communication across virtually any device, including 2-way radios, phones, computers, pagers, public and industrial warning systems, sirens and more. Disparate radio systems can be bridged by docking radios into the mobile command and control unit or stationary unit. With the Federal Signal SmartMsg system, communications equipment is linked to enable various entities to work together seamlessly during emergency incidents and planned events.

The system also provides distributed instant messaging architecture that features instant scalability, redundancy and automated fail-over in support of thousands of users across hundreds of servers. Fully integrated alert notification reaches PCs, wireless handheld devices like pocket PCs, PDAs and cellular phones, along with landline phones, pagers, video enabled devices and radios. The Federal Signal SmartMsg system offers secure and encrypted communication for alert notifications, voice-over-IP (VoIP) communication, radio linked talk groups and two-way text or voice communication.



St Bernards Regional Medical Center Jonesboro, Arkansas

St. Bernards Medical Center is a 400+ bed acute care hospital serving Northeast Arkansas and Southeast Missouri. Their Emergency Room is one of the busiest in the state. St. Bernards recognized the importance to improve the effectiveness of communication among caregivers, improve the safety of using high-alert medications, and to improve the effectiveness of clinical alarm systems. In March 2008 St. Bernards obtained a grant for emergency response systems and selected Codespear for interoperable communications and notifications solutions.

The system alerts all key hospital personnel during a crisis and is utilizing custom response features to monitor estimated response time of staff and respond accordingly (i.e. making subsequent alerts to other groups for mutual aid. In addition to implementing Codespear SmartMsg on site, the decision was made to integrate the Jonesboro Fire Department into the system to allow additional communication within each group and between the hospital and fire department. Jonesboro fire department will access system via the Web Client.

Purchasing Considerations

- Where is the company headquartered?
 - Federal Signal is headquartered in Chicago. Codespear, a Federal Signal Company, is headquartered in Birmingham, Michigan.
 - Codespear is part of the Federal Signal Public Safety Systems Division which is comprised of first responders, industry architects, lead engineers, and software development expertise that is best in the industry.
- Does the company have significant experience in Interoperable Communications, Alerting, and Notification systems?
 - Codespear is an industry leader in Interoperable Communications, and has been designing and manufacturing solutions for the past 7 years and Federal Signal has been developing interoperable communications solutions for over 75 years.
- How many SmartMsg systems have been deployed?
 - Codespear is approaching over 100 installations throughout North America.
 - Codespear provides not only an interoperable communication platform but provides software modules, radio interoperability devices and cables, and sensor boxes all based on a robust back office server platform that allows you to quickly scale to support your needs.
- How long has the company been serving the public safety market?
 - Federal Signal has been addressing the needs of the public safety market for over 100 years. Codespear is responsible for many North America's largest installations of alerting and notifications systems.
- What is the financial viability of the company...will they be around in 10 years to provide support?
 - Federal Signal is a \$1.3 billion publicly traded company (NYSE: FSS) with over 5,000 worldwide employees.
- Does the company provide a thorough and diverse list of references that will speak to their satisfaction with the product, the service, and the results?
 - Federal Signal is widely known to be one of the most trusted names in public safety, and can provide a list of references that is unmatched by any other company.
 - In the healthcare field references include but are not limited to Michigan Region 1 Regional Medical Response Coalition, Oakwood Hospital System, Mercy Hospital System, St. Bernard's Regional Hospital, Children's Hospital in Arkansas, and Crittenden Regional Hospital
 - Likewise, Codespear Technology is the clear leader in Interoperable Communications for other first responder needs and maintains a very broad base of satisfied customers including many leading organization around the globe. This includes a vast array of

communities, commercial customers, law enforcement agencies, and universities that include but are not limited to; Michigan State Police - Emergency Management and Homeland Security Division, Wayne County, Michigan - Emergency Management and Homeland Security Division, Omaha Tri-County UASI Region, Kentucky State Police, Mohave County, Arizona, City of Phoenix – Sky Harbor Airport, Chrysler, LLC (Formerly DaimlerChrysler), Ford Motor Company, NYCE Payments Network, Abbeville, South Carolina, Webber International University, Bloomfield Hills, Michigan, Air National Guard, NYC DOITT, and Livingston County HazMat.

- For more information please visit our public safety systems news and information site at: <http://www.fspublicsafetysystems.com/index.php?/news/>
- Does the company maintain design and manufacturing control for all components of the solution?
 - Codespear designs, develops, and assembles all components of its solution including software, API's, protocols, servers, devices, interoperability units, and radio cables, communications engines, and software applications.
- Does the company offer various application programming interfaces (API) for specific products available in the market place?
 - Federal Signal Codespear maintains a staff of experienced and dedicated interface and integration engineers to respond to the frequent changes seen in application programming interface and device interoperability requirements within the North American market.
- You mention several times that Codespear is a platform. We already have a platform and a lot of other software solutions installed. What do we do next?
 - Codespear works as an add on connectivity layer to your existing communications and software platforms that you may already have installed. It has been designed to stand alone but also easily connects to augment your existing technologies.
 - Selected Module / Interfaces examples include but are not limited to:
 - Text to Speech
 - Language Translation
 - SIP
 - H323
 - PSTN
 - SMS
 - SMTP
 - Pager
 - Fax
 - Pocket PC
 - HTML
 - Extensible Markup Language (“XML”)
 - Incident management platforms:
 - E-Team
 - Previsstar (Formerly RamSafe)
 - Microsoft Active Directory – LDAP, Novell eDirectory - LDAP
 - Panic Button
 - Video
 - Data Logger
 - Sensors (motion sensors, contact switches, temperature, etc.)
 - RFID
 - GPS
 - Instant Messenger
 - Common Alerting Protocol (“CAP”)
 - GIS (e.g. ESRI)
 - National Weather Service

Summary and Next Steps

Codespear provides this integrated offering to help enable interoperable communications, alerting and notification systems within the healthcare industry.

Codespear is the leader in communication solutions that can touch virtually any device type and work over any medium. Its SmartMsg platform currently has the ability to reach overhead paging systems, radios, cell phones, pagers, loudspeakers, desktop and laptop computers, landline phones, sat phones, PDAs (PocketPC, Blackberry, etc.) simultaneously. Codespear's platform/foundation also provides for rapid development of new interfaces to accommodate new device types or protocols very easily. In addition, SmartMsg also has a full range of API's (application programming interface) that can enable the sending of specialized messages to other communications, alerting and notification systems automatically.

For more information please visit us at <http://www.federal-signal.com/public-safety> or visit our Codespear site and knowledge base at <http://www.codespear.com> .

You can also reach us anytime at: 1.800.548.7229